

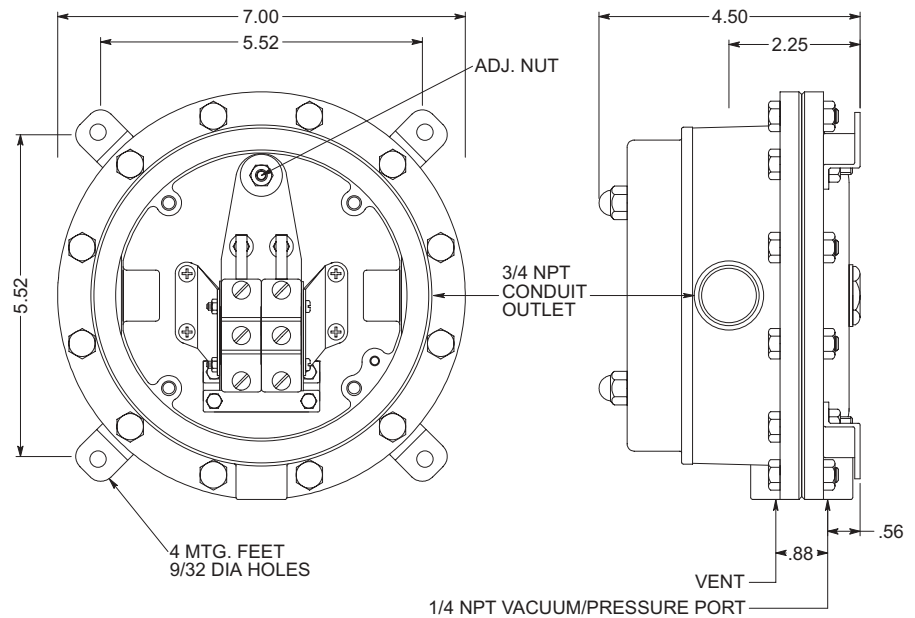

- Ranges from 3 W.C. To 0-100 W.C.
- Rugged NEMA 4X & 12 Housing Std.
- Class I, Div. I, Gr. C & D Available
- Up to Four SPDT Contacts
- Various Wetted Materials Available

## MODEL SERIES 7PS Vacuum/Pressure Switch Diaphragm Sensing Element



### GENERAL DESCRIPTION

The Model Series 7PS Vacuum/Pressure Switch is designed for low vacuum and pressure application where it is useful to have both pressure and vacuum settings in one device. These switches are very versatile and can be built with up to four set points either above and / or below atmospheric with just one process connection. This device employs Solon's sensitive and rugged switching mechanism. Unlike most "inline" switch designs, the Solon mechanism is frictionless and amplifies the movement of a large area diaphragm. This results in improved life, repeatability, and lower deadbands.

The rugged, cast aluminum housing can be specified 7PSW, watertight; or 7PSX, explosion proof. The housing is large enough to accommodate up to four full size S.P.D.T. electric switches.

In addition many switching configurations can be supplied with electric switches that have:

- Low switch differentials (dead band).
- High direct current ratings.
- Gold contacts.
- Hermetically sealed contacts.

The standard sensing element uses a strong Buna N elastomer diaphragm. Other diaphragm and wetted area materials are available. See the Special Features section on page 2 for other materials and other options that are useful for particular applications.

### SPECIFICATIONS

#### PHYSICAL DATA (Standard)

-see page 2 for special features

**Maximum Ambient Temperature:** 180°F

**Minimum Ambient Temperature:** -20°F

**Vacuum/Pressure Connection:** 1/4 NPT

**Electrical Connection:** 3/4 NPT

**Housing:** Cast Aluminum

**Deadband:** Fixed

**Sensitivity:** 1/2% of range (for one SPDT Switch)

**Drift:** <1% of range (100,000 operations)

**Weight:** Approx. 6 lbs.

**Contact Ratings:** 15A - 125, 250, 480 VAC

**Port Material:** Aluminum

**Diaphragm Material:** Buna N

**Set Point Adjustment:** Screw type, field adjustable

**No. Contacts:** 1, 2, 3 or 4 S.P.D.T or 1 D.P.D.T.

**Contact Listings:** UL Recognized, CSA Certified



Underwriters Laboratories, Inc. Listed:  
Industrial Controls Equipment Type 4 & 12, File E130423,  
Pressure Operated Switch for Hazardous Locations,  
Class I, Groups C & D; Class II, Groups E, F, & G File E65371.



Canadian Standards Association Certified:  
Industrial Control Equipment Type 4 & 12, LR88975.  
Switches Pressure Type for Hazardous Locations,  
Class I, Groups C & D; Class II, Groups E, F & G, LR88975.

### Solon Manufacturing Company

425 Center Street, P.O. Box 207, Chardon, Ohio 44024  
(440) 286-7149 800-323-9717 FAX (440) 286-9047  
www.solonmfg.com

# ORDERING A SWITCH

## 1. SPECIFY A MODEL NUMBER

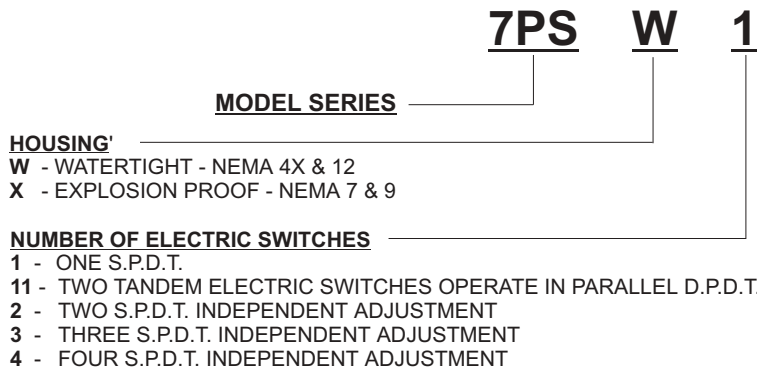

- SPECIAL FEATURES**  
**"-** - NO SPECIAL FEATURES  
**A** - ADJUSTABLE DEADBAND (ADJ. 10% - 50% OF RANGE)  
**E** - EXTERNAL ADJUSTMENT  
**EE** - TWO EXTERNAL ADJUSTMENTS  
**G** - DOUBLE DIAPHRAGM EXTRA SENSITIVE LOW VAC.  
**J** - SAFETY SEAL  
**L** - ONE INDICATOR LIGHT (NOT ON X HOUSING)  
**LL** - TWO INDICATOR LIGHTS (NOT ON X HOUSING)  
**M** - MALE PIPE MOUNTING 1/2 NPT  
**P** - PANEL MOUNTING  
**R>** - MANUAL RESET, SWITCH ON INCR. VAC.  
**R<** - MANUAL RESET, SWITCH ON DECR. VAC.  
**SS** - SPECIAL TRIM BASE 316 STAINLESS STEEL  
**SI** - SPECIAL TRIM BASE TEFLON (NOT ON X SWITCHES)  
**SY** - SPECIAL TRIM BASE PVC (NOT ON X SWITCHES)  
**U** - ADDITIONAL PAINTING AFTER ASSEMBLY  
**V** - HIGH TEMPERATURE SERVICE - NOT A UL OR CSA LISTED FEATURE  
**Z** - VITON DIAPHRAGM

# MODEL SERIES 7PS Vacuum/Pressure Switch Diaphragm Sensing Element

### TYPE OF ELECTRIC SWITCHES

- 1** - LOW DEADBAND  
 15A - 125, 250, 480 VAC
- 2** - STANDARD DEADBAND  
 15A - 125, 250, 480 VAC; 0.5A - 125 VDC
- 3** - HIGH DC RATED (MAGNETIC BLOWOUT)  
 10A - 125 VDC; 3A - 250 VDC
- 4** - HERMETICALLY SEALED SWITCH  
 1A-125VAC; 25A.RES, 10A.IND, 5A.MOTOR  
 3A.LAMP-28VDC
- 6** - GOLD CONTACT -  
 1 A - 125 VAC

\* SPECIAL FEATURES SUCH AS STAINLESS TAGGING, OR SPECIAL WETTED PARTS; KYNAR, KALREZ, HASTELLOY, ETC. ARE AVAILABLE ON REQUEST. CONSULT FACTORY FOR CAPABILITES AND PRICING FOR ANY FEATURES NOT SHOWN.

## DEADBAND NOTES

The deadbands listed in the tables are the maximum switch differentials when the Type "1" or Type "2" electric switch is used.

Deadband is affected by the type of electric switch used. Each type of electric switch's effect on deadband is as follows:

**Type "1"** - Low Deadband - Use table values.

**Type "2"** - Std. Deadband - Use table values.

**Type "3"** - High DC Rated - Multiply TYPE 2 table values by two.

**Type "4"** - Hermetically Sealed Switch - Multiply TYPE 2 table values by six.

**Type "6"** - Gold Contact - Use TYPE 2 table values.

For D.P.D.T., 2, 3 or 4 S.P.D.T. switches multiply calculated value from above by 1.5 to 2.

## 2. SPECIFY A RANGE

ADJUSTABLE RANGE	MAXIMUM DEADBAND WC		MAX. WORKING PRESSURE
	TYPE "1"	TYPE "2"	
-3/0/3 WC	.45 WC	.87 WC	25 PSI
-6/0/6 WC	.8 WC	1.6 WC	25 PSI
-15/0/15 WC	1.7 WC	3.4 WC	25 PSI
-30/0/30 WC	2.5 WC	5.0 WC	25 PSI
-60/0/60 WC	4.8 WC	9.6 WC	25 PSI
-100/0/100 WC	8.0 WC	16.0 WC	25 PSI

## INSTALLATION NOTES

**Orientation** - The 7PS will operate satisfactorily in any position, however, mounting the device vertically will allow the easiest adjustability and reduce sediment in the vacuum/pressure chamber.

**Wiring** - Switches may be wired to 'normally open' or 'normally closed' terminals on electric switch(es).

**Process Connection** - 1/4 NPT female is standard. 1/2 NPT male is available ("M" option).

**Adjustment** - Turn vacuum adjustment nut(s) clockwise to increase setpoint. Detailed installation & calibration instructions are provided for every shipment. Factory setting is available at no charge.

## Wiring Schematic

